

MODENA

95x255x204 (160x200)



95x255x224 (180x200)



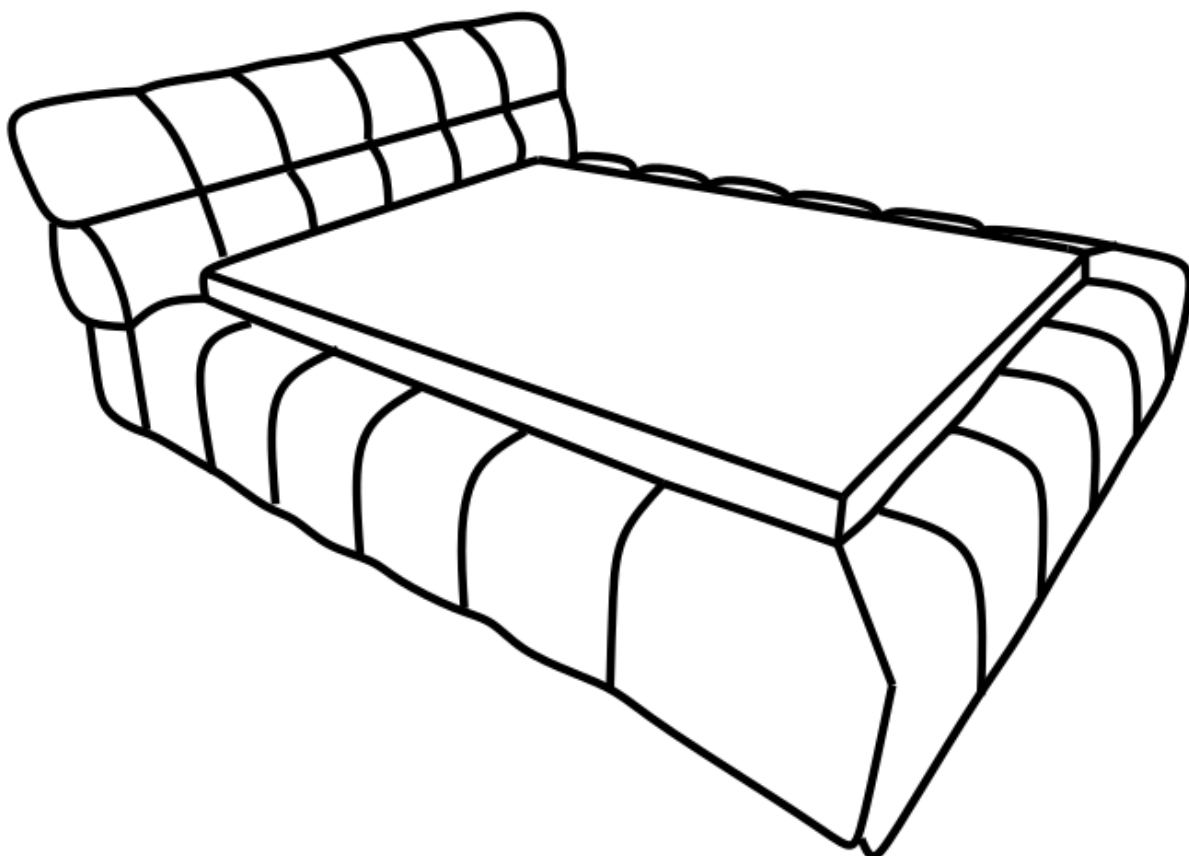

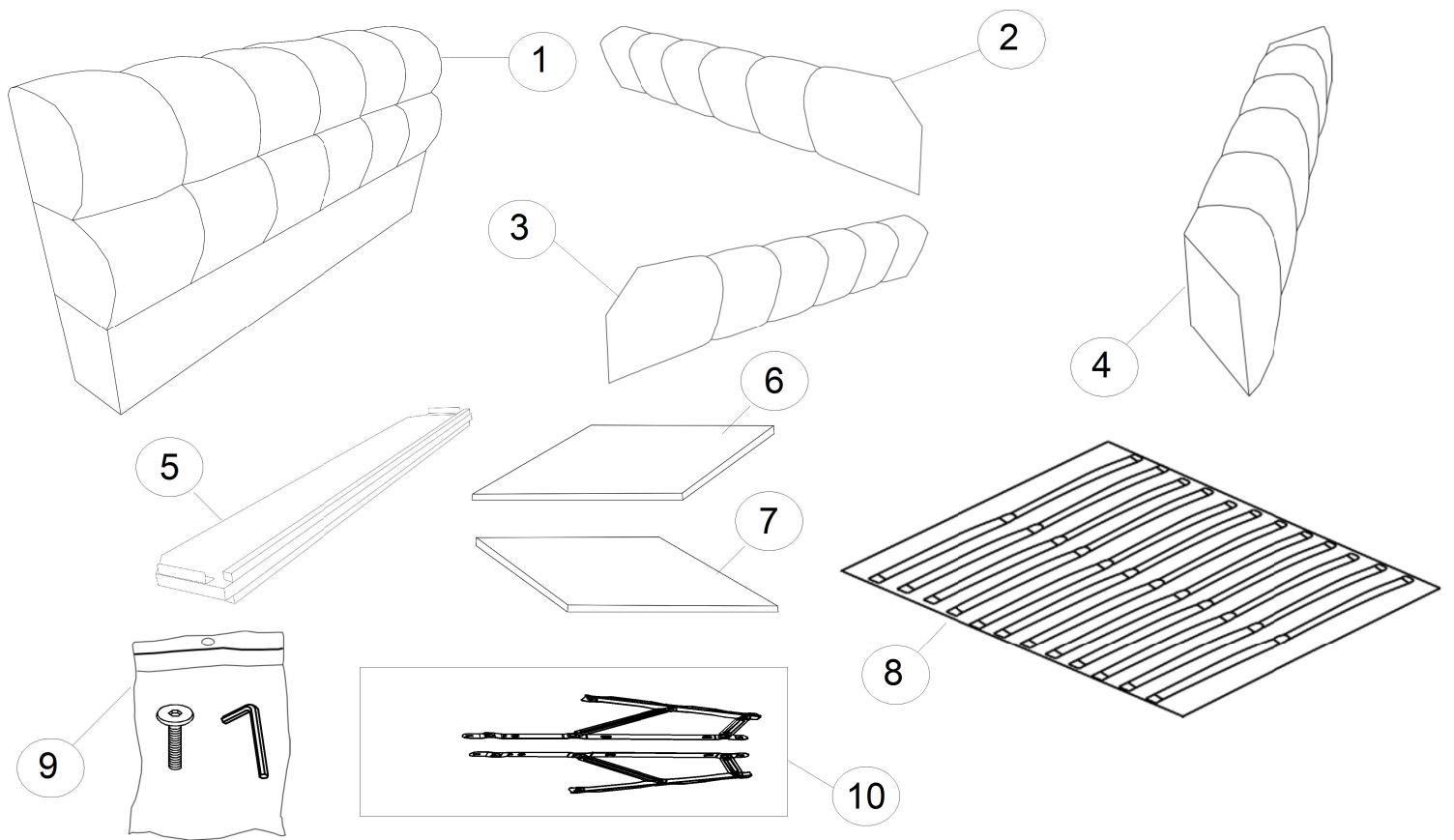



10,13 mm ca.1H

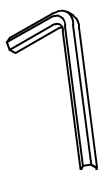
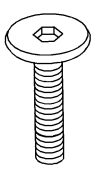

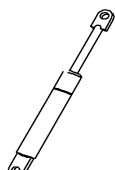
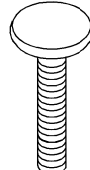
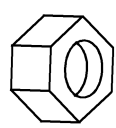

#			
1	950x2040x380mm (160x200)/ 950x2240x380mm (180x200)/ 950x2440x380mm (200x200)	1	3
2	440x240x2200mm (160x200)(180x200)(200x200)	1	1
3	440x240x2200mm (160x200)(180x200)(200x200)	1	1
4	440x2000x240mm (160x200)/ 440x2200x240mm (180x200)/ 440x2400x240mm (200x200)	1	2
5	230x1600x70mm (160x200)/ 230x1800x70mm (180x200)/ 230x2000x70mm (200x200)	1	1
6	3x1610x1030mm (160x200)/ 3x1810x1030mm (180x200)/ 3x2010x1030mm (200x200)	1	5
7	3x1610x950mm (160x200)/ 3x1810x950mm (180x200)/ 3x2010x950mm (200x200)	1	5
8	70x1595x1995mm (160x200)/ 70x1795x1995mm (180x200)/ 70x1995x1995mm (200x200)	1	4
9	20x170x100mm (160x200)(180x200)(200x200)	1	3
10	65x785x110mm (160x200)(180x200)(200x200)	1	6

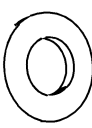
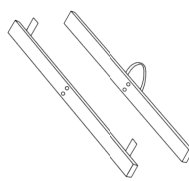
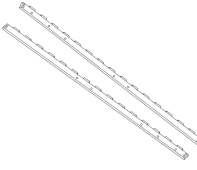
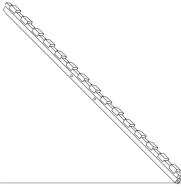
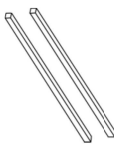
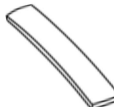
A	1	B	20	C	1/1	D	2	E	4	F	4	G	4
													
		6x25						6x65		M6		M8	

H	4	I	1/1	J	1/1	K	1	L	2	M	30	N	16
													
M6												6,4x50	

INSTRUKCJA BEZPIECZEŃSTWA I UŻYTKOWANIA ŁÓŻEK

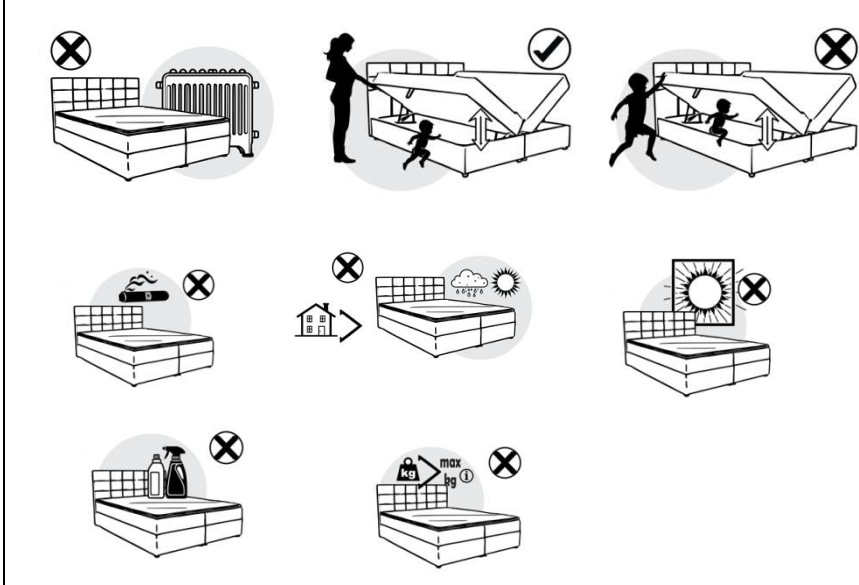
<p>EN - BED SAFETY AND USE INSTRUCTIONS</p> <p>DE- SICHERHEITS- UND GEBRAUCHSANWEISUNGEN FÜR DAS BETT</p> <p>ES- INSTRUCCIONES DE USO Y SEGURIDAD DE LA CAMA</p> <p>POT- SEGURANÇA DA CAMA E INSTRUÇÕES DE UTILIZAÇÃO</p> <p>IT- SICUREZZA DEL LETTO E ISTRUZIONI PER L'USO</p> <p>NEL- BEDVEILIGHEID EN GEBRUIKINSTRUCTIES</p> <p>FR- INSTRUCTIONS DE SÉCURITÉ ET D'UTILISATION DU LIT</p>	
---	--

Powierzchnię należy czyścić wilgotną szmatką lub specjalnymi detergentami. Rozlane ciecze należy natychmiast usunąć czystym i suchym przetrarciem, aby wchłonąć płyn. Nie trzyj, może to spowodować uszkodzenie tkaniny. Mogą pojawić się różnice w kolorze pomiędzy powierzchniami oczyszczonymi i nieoczyszczonymi. W razie wątpliwości należy skontaktować się ze specjalistą w celu przeprowadzenia czyszczenia

Surface shall be cleaned with moist cloth or with dedicated detergents. Spills should be removed immediately with a clean and dry dabbing to absorb the liquid. Do not rub, it may damage the fabric. Variations in color between the surfaces cleaned and uncleaned might appear. If in doubt, contact a professional to carry out cleaning.

Die Oberfläche muss mit einem feuchten Tuch oder speziellen Reinigungsmitteln gereinigt werden. Verschüttete Flüssigkeiten sollten sofort mit einem sauberen und trockenen Tupfer entfernt werden, um die Flüssigkeit aufzusaugen. Nicht reiben, da dies den Stoff beschädigen könnte. Es kann zu Farbabweichungen zwischen gereinigter und ungereinigter Oberfläche kommen. Wenden Sie sich im Zweifelsfall an einen Fachmann, um die Reinigung durchführen zu lassen.

La superficie se limpiará con un paño húmedo o con detergentes específicos. Los derrames deben eliminarse inmediatamente con un paño limpio y seco para absorber el líquido. No frotar, puede dañar la tela. Pueden aparecer variaciones de color entre las superficies limpiadas y sin limpiar. En caso de duda contacta con un profesional para realizar la limpieza.

A superfície deve ser limpa com pano úmido ou com detergentes específicos. Os derramamentos devem ser removidos imediatamente com um pano limpo e seco para absorver o líquido. Não esfregue, pode danificar o tecido. Podem aparecer variações de cor entre as superfícies limpas e não limpas. Em caso de dúvida, procure um profissional para realizar a limpeza.

La superficie dovrà essere pulita con un panno umido o con detergenti dedicati. Le fuoriuscite devono essere rimosse immediatamente con un panno pulito e asciutto per assorbire il liquido. Non strofinare, potrebbe danneggiare il tessuto. Potrebbero apparire variazioni di colore tra le superfici pulite e quelle non pulite. In caso di dubbi, rivolgersi ad un professionista per effettuare la pulizia.

Het oppervlak moet worden gereinigd met een vochtige doek of met speciale reinigingsmiddelen. Gemorste vloeistoffen moeten onmiddellijk worden verwijderd door schoon en droog te deppen om de vloeistof te absorberen. Niet wrijven, dit kan de stof beschadigen. Er kunnen kleurvariaties optreden tussen de gereinigde en ongereinigde oppervlakken. Neem bij twijfel contact op met een professional om de reiniging uit te voeren.

La surface doit être nettoyée avec un chiffon humide ou avec des détergents dédiés. Les déversements doivent être éliminés immédiatement avec un tampon propre et sec pour absorber le liquide. Ne frottez pas, cela pourrait endommager le tissu. Des variations de couleur entre les surfaces nettoyées et non nettoyées peuvent apparaître. En cas de doute, contactez un professionnel pour effectuer le nettoyage.

1

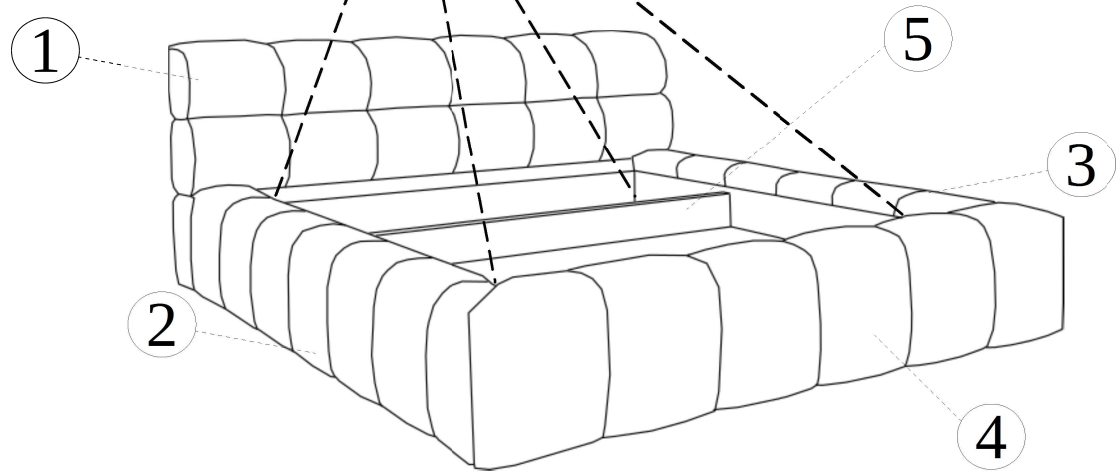
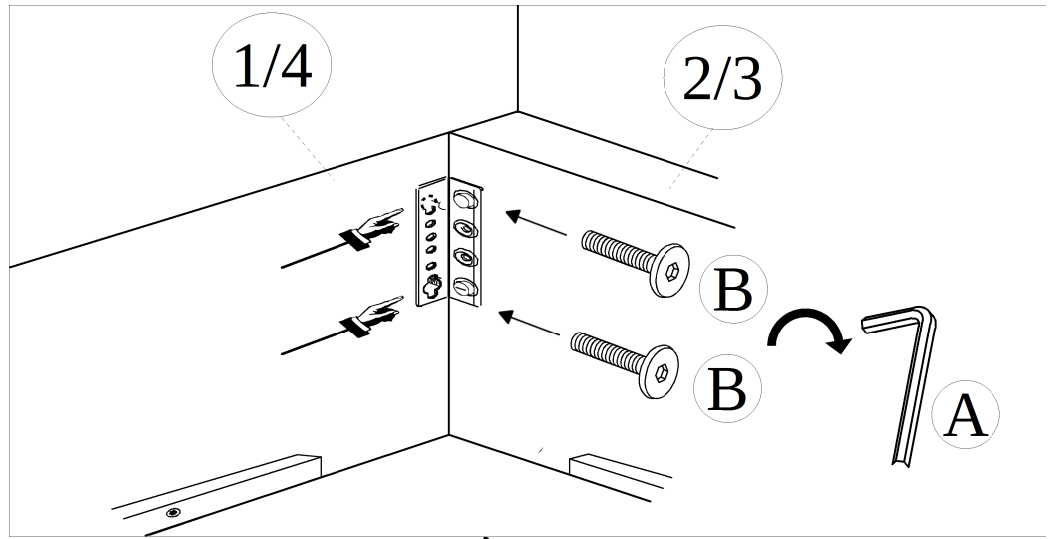

2

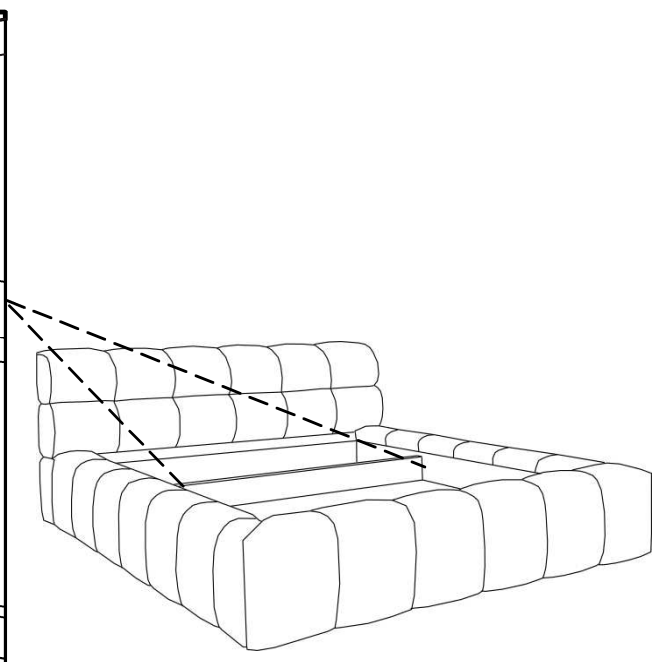
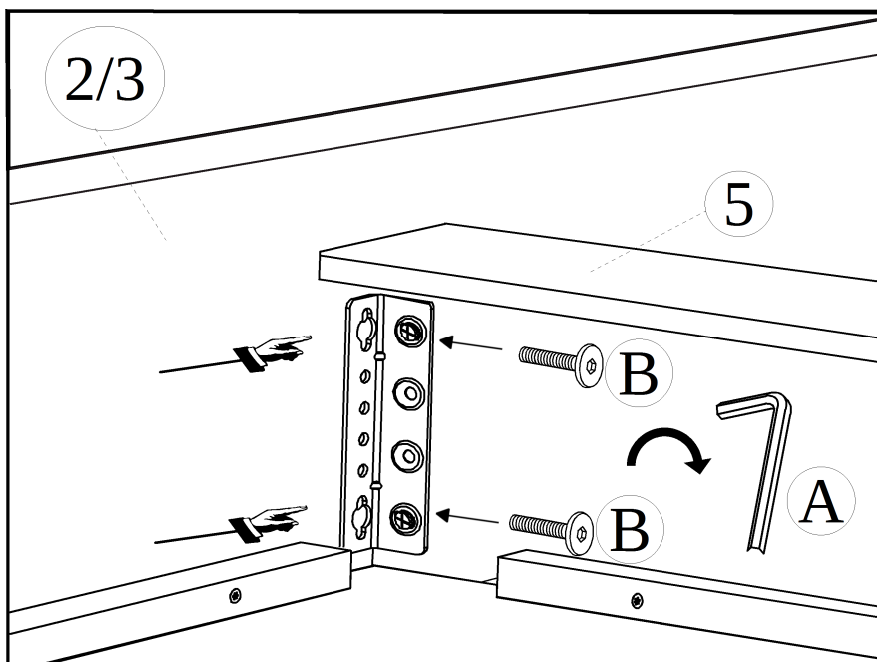

3

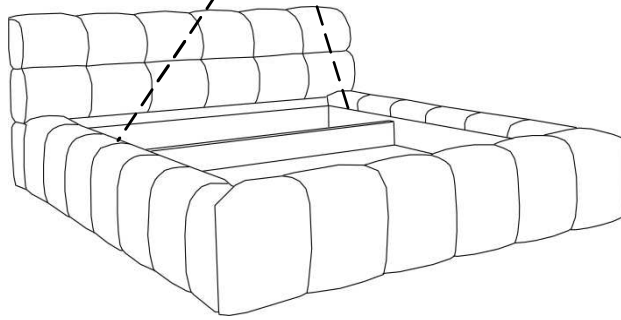
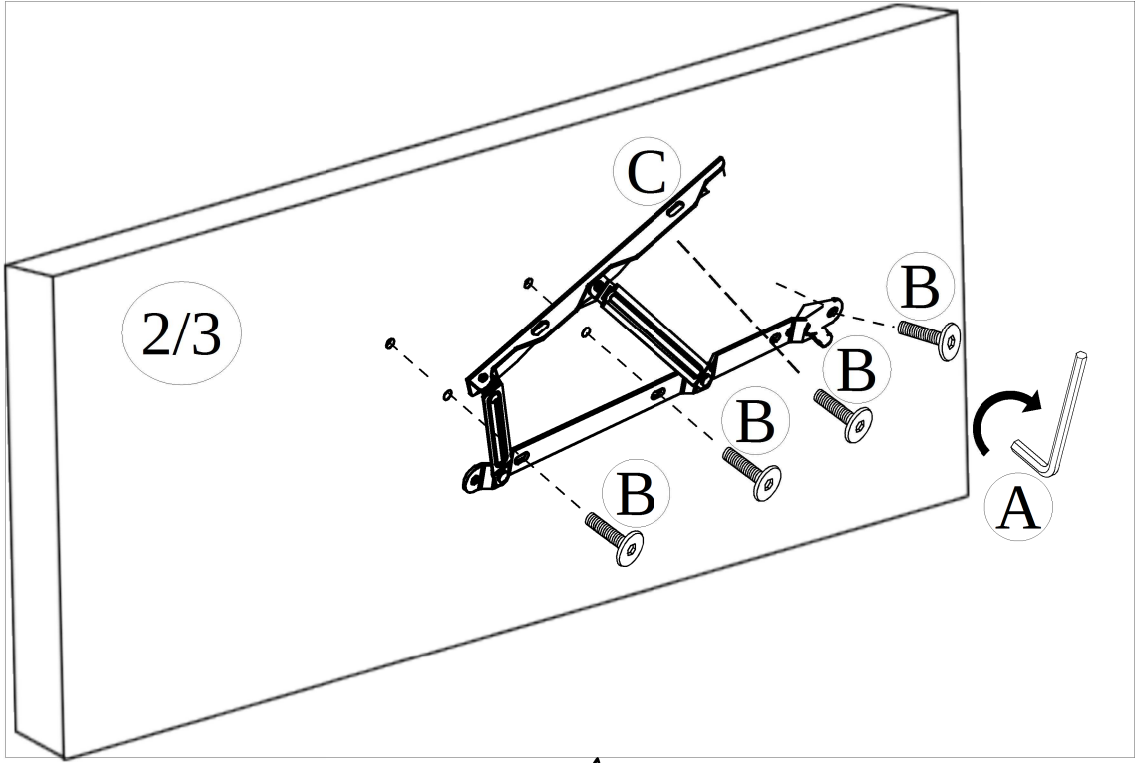

4

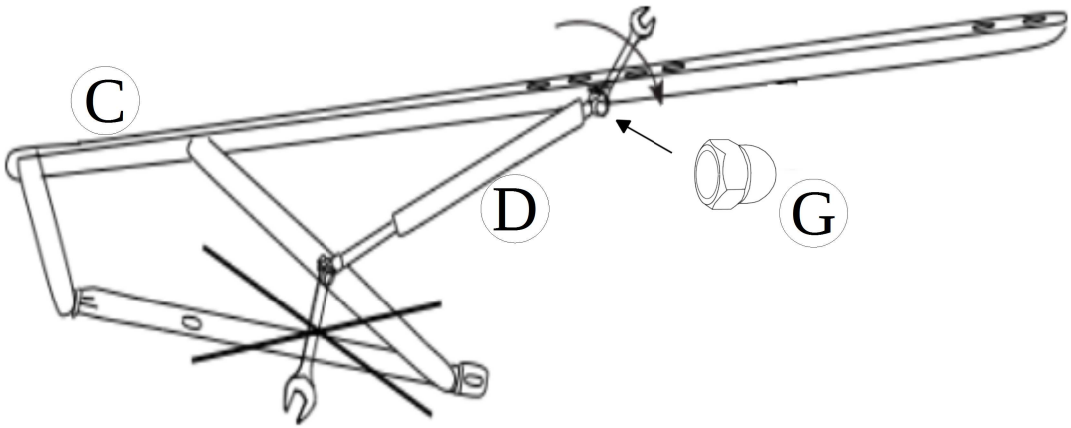

5

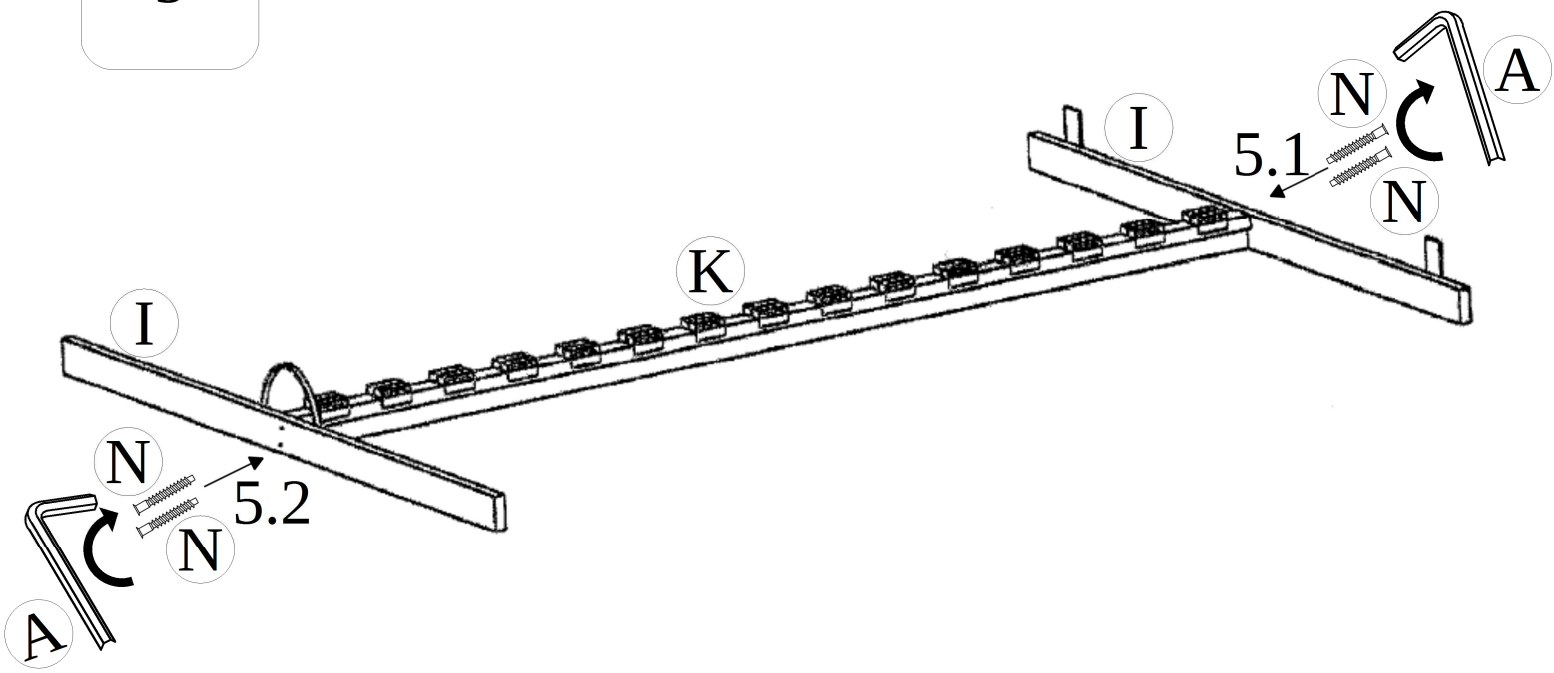

6

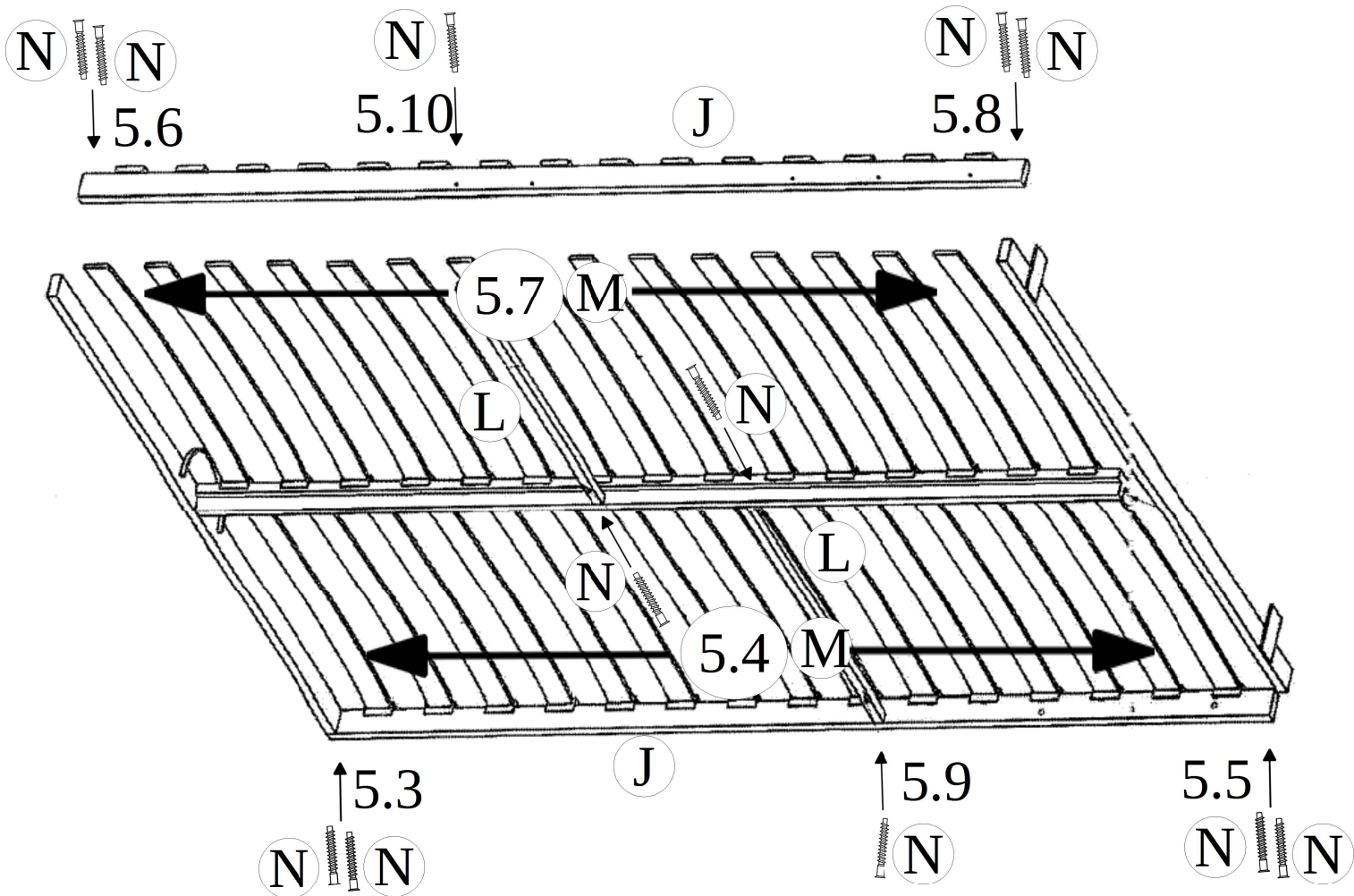

7

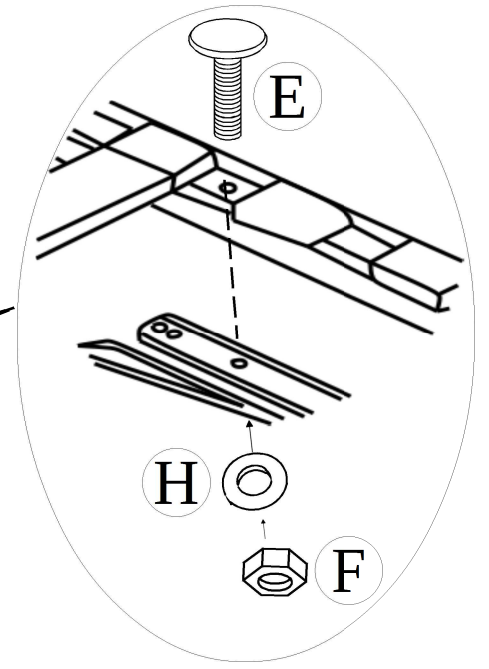
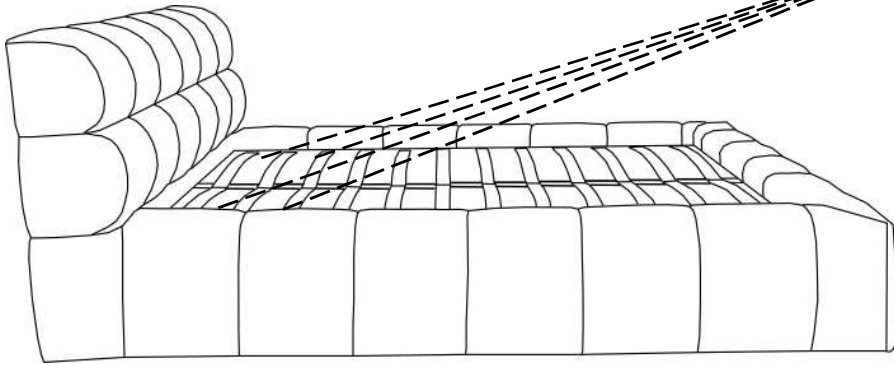

8

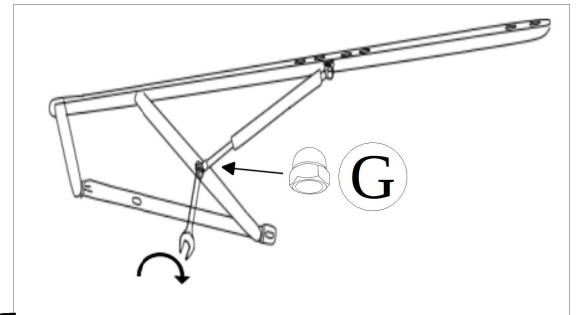
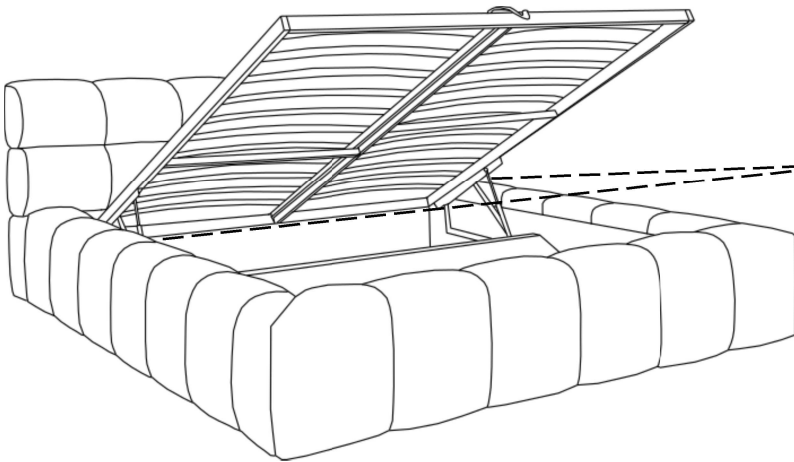

9

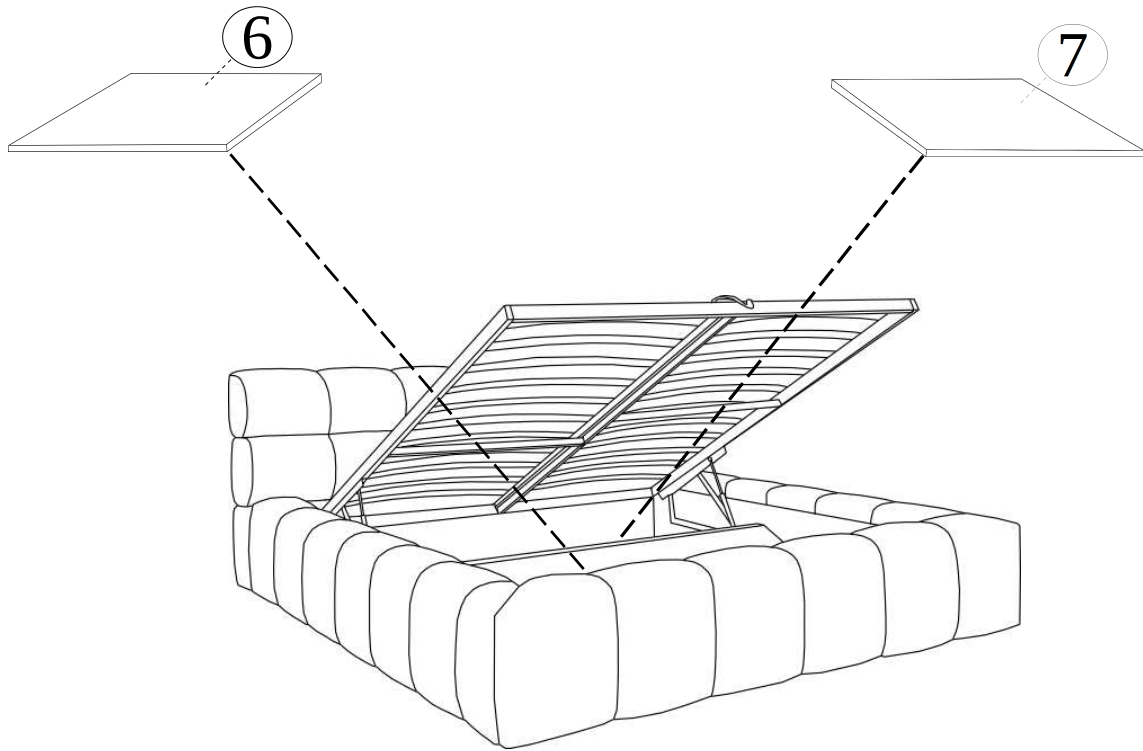

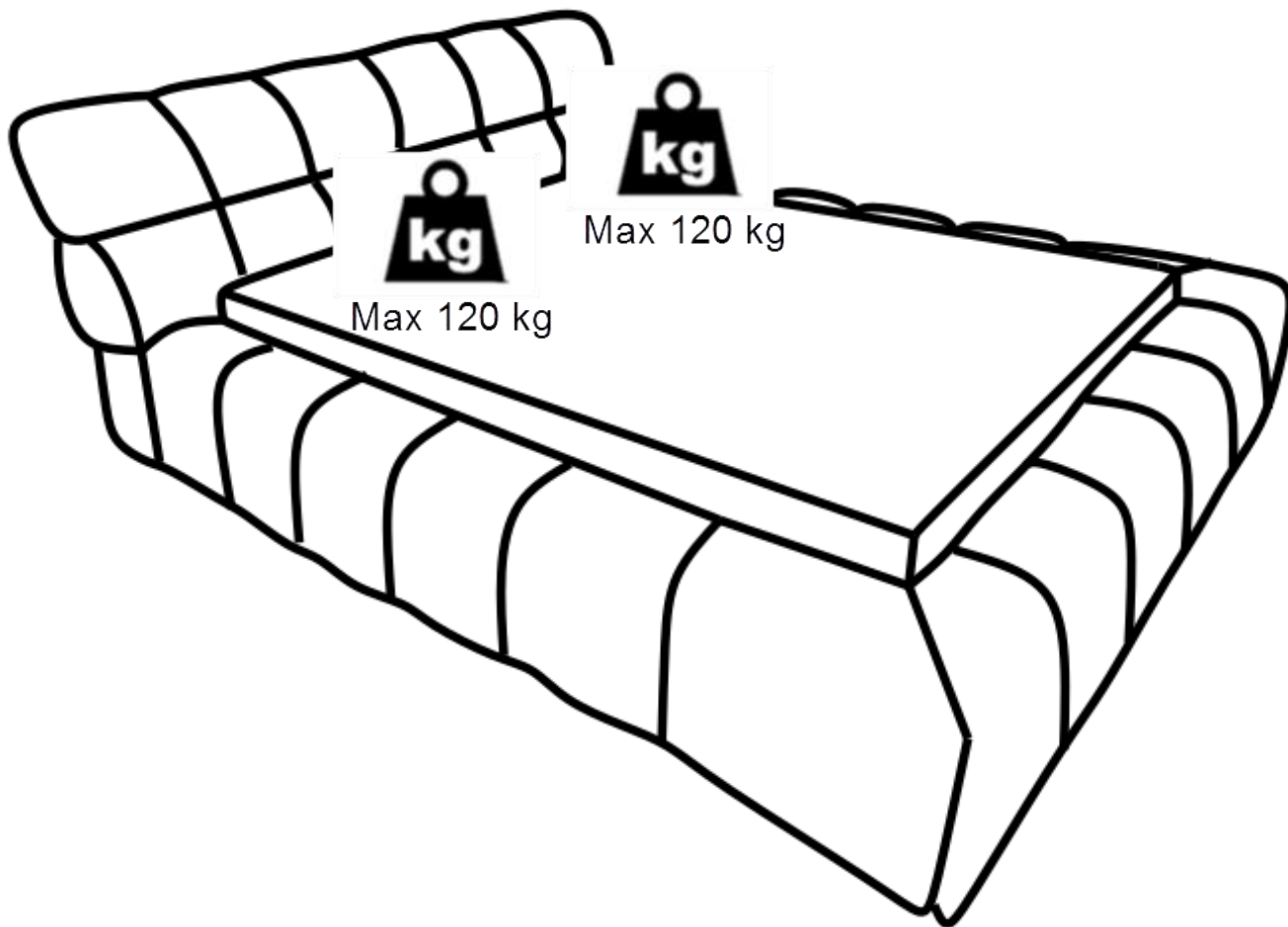

Wyprodukowano w Polsce / Made in Poland/ Hergestellt in Polen/ Hecho en Polonia/ Prodotto in Polonia/ Gemaakt in Polen/ Feito na Polônia/ Fabriqué en Pologne

GAWIN Sp. z o.o.

Królewska Wola 8b

56-513 Międzybórz

NIP 9112027463

biuro@gawin.pl